

## High-Speed Pressure Transducer

# CPT6140





**Warning**

**This Warning symbol indicates that danger of injury for persons and the environment and/or considerable damage (mortal danger, danger of injury) will occur if the respective safety precautions are not taken.**



**Caution**

**This Caution symbol indicates danger for the system and material if the respective safety precautions are not taken.**



**Notice**

**This Notice symbol does not indicate safety notices but information for a better understanding of the facts.**

## Contents

1. General Information . . . . .	5
1.1 Warranty . . . . .	5
1.2 Important Notice . . . . .	5
1.3 Software License Agreement . . . . .	6
1.4 Mensor Service Plus . . . . .	6
1.4.1 After the Warranty . . . . .	6
1.4.2 Calibration Services . . . . .	6
1.4.3 Certifications and Accreditations . . . . .	6
2. Safety Notices . . . . .	7
2.1 Warnings and Caution Notices . . . . .	7
3. Product Description . . . . .	8
3.1 General Description . . . . .	8
3.2 Power Supply . . . . .	8
3.3 Sensor . . . . .	8
3.4 Circuitry . . . . .	8
3.5 Serial In/Out Communications . . . . .	8
4. Specifications . . . . .	10
5. Installation . . . . .	12
5.1 Unpacking . . . . .	12
5.2 Dimensions . . . . .	12
5.3 Configuration . . . . .	12
5.4 Mounting . . . . .	12
5.5 Pressure Connections . . . . .	13
5.6 Electrical Connections . . . . .	13
5.6.1 Connector J1 Wiring . . . . .	14
5.6.2 RS-232 Operation . . . . .	14
5.6.3 RS-485 Operation . . . . .	14

# High-Speed Pressure Sensor CPT6140

6. Operation . . . . .	15
6.1 Serial Port Configuration . . . . .	16
6.2 CPT6140 Address . . . . .	16
6.3 Communication Output Modes . . . . .	16
6.4 Communication Syntax and Command Conventions . . . . .	17
6.4.1 Password Protection . . . . .	17
6.4.2 Response String Format . . . . .	17
6.4.3 Commands and Queries . . . . .	18
6.4.4 Pressure Unit Code and Conversion . . . . .	19
7. Calibration . . . . .	22
7.1 Environment . . . . .	22
7.2 Equipment . . . . .	22
7.3 Pressure Standard . . . . .	24
7.4 Calibration Medium . . . . .	24
7.5 Calibration Process . . . . .	24
7.6 Correction Value Query . . . . .	24
7.7 Zero Adjustment . . . . .	25
7.7.1 Gauge Zero Offset . . . . .	25
7.7.2 Absolute Zero Offset . . . . .	26
7.8 Span Adjustment . . . . .	27

## 1. General Information

### 1.1 Warranty

All products manufactured by Mensor are warranted to be free of defects in workmanship and materials for a period of two years from the date of shipment. No other express warranty is given, and no affirmation of Seller, by words or actions, shall constitute a warranty. SELLER DISCLAIMS ANY IMPLIED WARRANTIES OF MERCHANTABILITY OR FITNESS FOR ANY PARTICULAR PURPOSES WHATSOEVER. If any defect in workmanship or material should develop under conditions of normal use and service within the warranty period, repairs will be made at no charge to the original purchaser, upon delivery of the product(s) to the factory, shipping charges prepaid. If inspection by Mensor or its authorized representative reveals that the product was damaged by accident, alteration, misuse, abuse, faulty installation or other causes beyond the control of Mensor, this warranty does not apply. The judgment of Mensor will be final as to all matters concerning condition of the product, the cause and nature of a defect, and the necessity or manner of repair. Service, repairs or disassembly of the product in any manner, performed without specific factory permission, voids this warranty.

MENSOR MAKES NO WARRANTY OF ANY KIND WITH REGARD TO THIS MANUAL, INCLUDING, BUT NOT LIMITED TO, THE IMPLIED WARRANTIES OF MERCHANTABILITY AND FITNESS FOR A PARTICULAR PURPOSE. Mensor shall not be liable for errors contained herein or for incidental or consequential damages in connection with the furnishing, performance, or use of this material.

### 1.2 Important Notice

The product specifications and other information contained in this manual are subject to change without notice.

Mensor has made a concerted effort to provide complete and current information for the proper use of the equipment. If there are questions regarding this manual or the proper use of the equipment, contact either Mensor or WIKA:

Mensor  
201 Barnes Drive  
San Marcos, TX 78666  
tel: 1-512-396-4200  
1-800-984-4200 (USA only)  
website: [www.mensor.com](http://www.mensor.com)  
fax: 1-512-396-1820  
email: [sales@mensor.com](mailto:sales@mensor.com)  
[tech.support@mensor.com](mailto:tech.support@mensor.com)

WIKA Alexander Wiegand SE & Co. KG  
Alexander-Wiegand-Straße 30  
D-63911 Klingenberg / Germany  
tel: (+49) 93 72/132-5015  
website: [www.wika.de](http://www.wika.de)  
fax: (+49) 93 72/132-8767  
email: [CTsales@wika.com](mailto:CTsales@wika.com)

Any reproduction of this manual or parts thereof by any means is prohibited.  
Copyright © 2005, Mensor. All rights reserved.

### **1.3 Software License Agreement**

This product contains intellectual property, i.e., software programs, that are licensed for use by the end user/customer (hereinafter “end user”).

This is not a sale of such intellectual property.

The end user shall not copy, disassemble or reverse compile the software program.

THE SOFTWARE PROGRAMS ARE PROVIDED TO THE END USER “AS IS” WITHOUT WARRANTY OF ANY KIND, EITHER EXPRESS OR IMPLIED, INCLUDING, BUT NOT LIMITED TO, WARRANTIES OF MERCHANTABILITY AND FITNESS FOR A PARTICULAR PURPOSE. THE ENTIRE RISK OF THE QUALITY AND PERFORMANCE OF THE SOFTWARE PROGRAM IS WITH THE END USER.

MENSOR AND ITS SUPPLIERS SHALL NOT BE HELD TO ANY LIABILITY FOR ANY DAMAGES SUFFERED OR INCURRED BY THE END USER (INCLUDING, BUT NOT LIMITED TO, GENERAL, SPECIAL, CONSEQUENTIAL OR INCIDENTAL DAMAGES INCLUDING DAMAGES FOR LOSS OF BUSINESS PROFITS, BUSINESS INTERRUPTION, LOSS OF BUSINESS INFORMATION AND THE LIKE), ARISING FROM OR IN CONNECTION WITH THE DELIVERY, USE OR PERFORMANCE OF THE SOFTWARE PROGRAM.

### **1.4 Mensor Service Plus**

If you have problems and you don't find the answer in this manual, contact Mensor at 1.800.984.4200 (USA only) or 1.512.396.4200 for personal assistance, or at any of the contact addresses listed on the rear cover of this manual. We are ready to help.

#### **1.4.1 After the Warranty**

Mensor's concern with the performance of this instrument is not limited to the warranty period. We provide complete repair, calibration and certification services after the warranty for a nominal fee.

#### **1.4.2 Calibration Services**

In addition to servicing our own products Mensor can perform a complete pressure calibration service, up to 30,000 psi, for all of your pressure instruments. This service includes an accredited calibration.

#### **1.4.3 Certifications and Accreditations**

Mensor is registered to ISO 9001:2008. The calibration program at Mensor is accredited by A2LA, as complying with both the ISO/IEC 17025:2005 and the ANSI/NCSL Z540-1-1994 standards.

## 2. Safety Notices

### 2.1 Warnings and Caution Notices



**Warning**

**Not explosion proof. Installation of this instrument in an area requiring devices rated as intrinsically safe is not recommended.**



**Caution**

**Some ranges require clean, dry, non-corrosive pressure media. See “Media Compatibility” in the Specifications section of this manual. This instrument is not designed for oxygen use.**



**Caution: ESD PROTECTION REQUIRED.** The proper use of grounded work surfaces and personal wrist straps are required when coming into contact with exposed circuits (printed circuit boards) to prevent static discharge to sensitive electronic components.



**Caution**

**Avoid excessive overpressure to the transducer. Externally mounted relief valves to provide overpressure protection are available from Mensor as optional devices and are highly recommended for very low pressure transducers.**

## 3. Product Description

### 3.1 General Description

The CPT6140 High-Speed Pressure Transducer is a self-contained pressure sensing device that provides high accuracy pressure measurements. The CPT6140 gives a streaming output at 250Hz from a low hysteresis silicon sensor with electronically compensated pressure linearity over the specified temperature range. Communication with the CPT6140 is over a RS-232 or RS-485 serial bus.

### 3.2 Power Supply

The required 12VDC power enters via J1. The power supply used to power the device must be a limited-energy device supplying less than 8.3A at 12VDC. It is recommended that the power supply is IEC 61010-1 3rd ed. compliant.

### 3.3 Sensor

The pressure sensor is a micromachined silicon strain gauge. The sensor is secured to the transducer case.

### 3.4 Circuitry

All of the circuitry is included on a single PC board. The combined pressure and temperature sensor signals are routed to the signal conditioning electronics.

### 3.5 Serial In/Out Communications

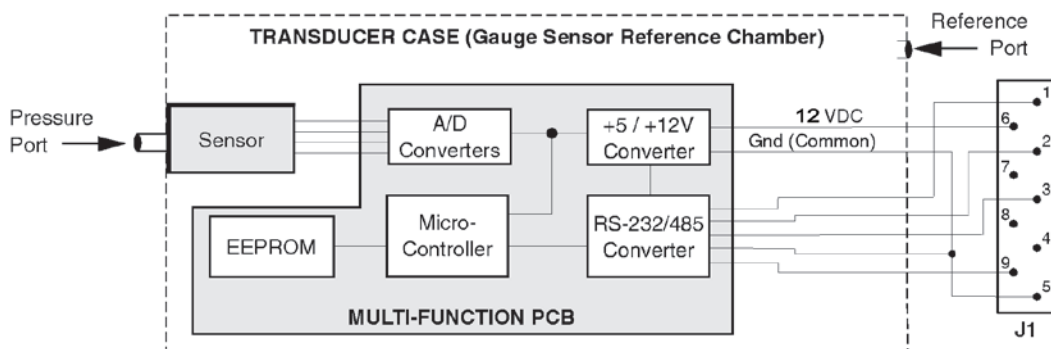

Figure 3.6 - Serial In/Out Communications



The serial bus is set to either RS-232 or RS-485 at the factory. The bus is a two way communication path used to receive commands and return measured pressure values and other transducer information to the user. This port is also used to transmit calibration adjustments and other user functions to the transducer. Pressure units for each transducer are specified by the customer. Wiring requirements for the serial port are provided in the Installation section and a list of valid commands and responses (Table 6.5.4) is provided in the operation section.

# High-Speed Pressure Sensor CPT6140

## 4. Specifications

Accuracy specifications presented herein are obtained by comparison with primary standards traceable to the National Institute of Standards and Technology (NIST). These specifications are obtained in accordance with the ISO Guide to the Expression of Uncertainty in Measurement (GUM). The calibration program at Mensor is accredited by the American Association of Laboratory Accreditation (A2LA) as complying with both the ISO/IEC 17025:2005 and the ANSI/NCSL Z540-1-1994 standards.

Mensor reserves the right to change specifications without notice.

### High-Speed Pressure Transducer Technical Specification

<b>Accuracy</b> <sup>1)</sup>	0.025 % FS <sup>2)</sup>	0.025 % IS-50 <sup>3)</sup>
<b>Measuring ranges</b>		
Gauge pressure	0 ... ≥ 70 mbar up to 0 ... 400 bar (0 ... ≥ 1 up to 0 ... 6,000 psi) <sup>4)</sup>	0 ... 1 up to 0 ... 400 bar (0 ... 15 up to 0 ... 6,000 psi) <sup>4)</sup>
Bi-directional	-35 ... +35 mbar up to -1 ... +400 bar (-0.5 ... +0.5 up to -14.5 ... +6,000 psi) <sup>4)</sup>	-1 ... +10 up to 0 ... 400 bar (-15 ... +145 psi up to 0 ... 6,000 psi) <sup>4)</sup>
Absolute pressure <sup>5)</sup>	0 ... 500 mbar up to 0 ... 401 bar abs. (0 ... 7.5 psi up to 0 ... 6,015 psi abs.)	0 ... 1 up to 0 ... 401 bar abs. (0 ... 15 up to 0 ... 6,015 psi abs.)
Precision <sup>6)</sup>	0.009 % FS	0.009 % FS
<b>Calibration interval</b>	180 days	365 days
<b>CPT6140 as barometric reference</b>		
Measuring range	552 ... 1,172 mbar abs. (8 ... 17 psi abs.)	
Accuracy <sup>1)</sup>	0.025 % of reading	
Calibration interval	365 days	
Pressure units	psi, bar, mbar, Pa, kPa, hPa, MPa, tsi, atm, torr, Dynes/cm <sup>2</sup> , g/cm <sup>2</sup> , kg/cm <sup>2</sup> , mSW, oz/in <sup>2</sup> , psf, tsf, mmH <sub>2</sub> O (4 °C), cmH <sub>2</sub> O (4 °C), mH <sub>2</sub> O (4 °C), inH <sub>2</sub> O (4 °C), inH <sub>2</sub> O (20 °C), inH <sub>2</sub> O (60 °F), ftH <sub>2</sub> O (4 °C), ftH <sub>2</sub> O (20 °C), ftH <sub>2</sub> O (60 °F), μmHg (0 °C), mmHg (0 °C), cmHg (0 °C), inHg (0 °C), inHg (60 °F), inSW (0 °C), ftSW (0 °C), mtorr (0 °C)	

1) It is defined by the total measurement uncertainty, with the coverage factor (k = 2) and includes the intrinsic performance of the instrument, the measurement uncertainty of the reference instrument, long-term stability, influence of ambient conditions, drift and temperature effects over the compensated range with recommended zero point adjustment every 30 days.

2) FS = full span

3) 0.01 % IS-50 accuracy: Between 0 ... 50 % of the full scale, the accuracy is 0.01% of half of the full scale value and between 50 ... 100 % of the full scale, the accuracy is 0.01 % of reading.

4) Ranges from 1500 to 2000 psig will be sealed gauge transducers.

5) The minimum calibrated range of absolute transducer(s) is 600mTorr

6) It is defined as the combined effects of linearity, repeatability and hysteresis throughout the stated compensated temperature range

## High-Speed Pressure Transducer General Specification

### Case

Mounting position	< 1 bar negligible Can be adjusted through zero point adjustment (linear shift of the characteristic curve)
Dimensions	See technical drawings
Weight	Approximately 17.8 ounces (505 grams)

### Display

Resolution	> 6 significant digits
Filter	Adjustable exponential filter from 0 ... 99 % The filter is only active within a defined range of 0.025 % FS.
Warm-up time	Approximately 15 min up to the specified accuracy

### Connections

Pressure connections	Connection 7/16-20 SAE for pressure and reference port The reference port is sealed for absolute pressure transducers
Overpressure limit	150 % FS
Material, wetted parts	Aluminium, brass, 316SS, Buna-N, Viton®, silicone grease, silicone rubber, nylon, ceramic, glass, silicon

### Voltage supply

Power supply	+12 VDC ±10%, 55mA max
--------------	------------------------

### Permissible ambient conditions (indoor use only)

Compensated temperature range	15 ... 45 °C (59 ... 113 °F)
Operating temperature range	0 ... 50°C (32 ... 122 °F)
Storage temperature range	0 ... 70 °C (32 ... 158 °F)
Humidity	0 ... 95 % r. h. (non-condensing)
Operating altitude	<3048 meters (10,000 ft)

### Communication

Interface	RS-232 or RS-485
Baud rate	57,600 baud
Measuring rate	250 values/s
Response time	4 ms for a FS pressure pulse

### Certificate

<b>Calibration</b>	Standard: A2LA calibration certificate Option: DKD/DAkkS calibration certificate
--------------------	---

Approvals and certificates, see website

# High-Speed Pressure Sensor CPT6140

## 5. Installation

### 5.1 Unpacking

In addition to functional testing, each unit is inspected for appearance prior to leaving the factory. Upon receipt, please examine the transducer for shipping damage. Report any apparent damage to the carrier immediately.

In addition to this manual and password information (files on USB drive), you should have:

- One High-Speed Pressure Transducer
- Any accessories ordered
- An envelope containing a Calibration Certificate

Note: The software utility is downloadable from the Mensor website (see Section 8.2, “Equipment”).

### 5.2 Dimensions

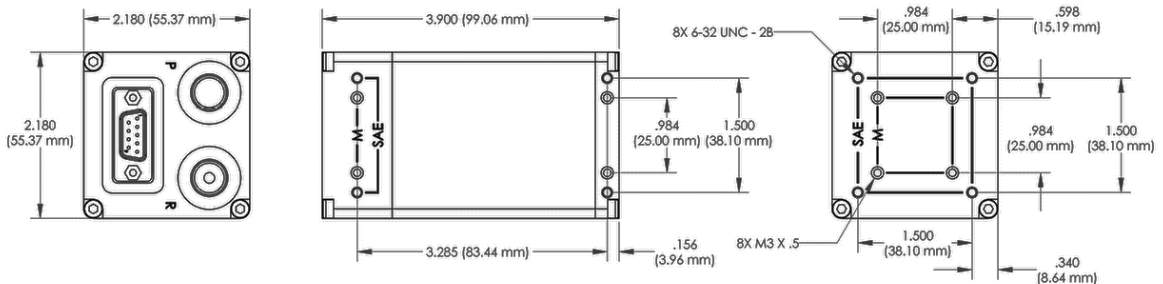

Mounting holes dimension could vary, slotted mounting holes are recommended.

### 5.3 Configuration

A typical system will consist of an IBM-PC compatible computer with installed driver software, one or more CPT6140's, a DC voltage power supply, and the interconnecting cables. The driver software can be any program configured to operate the appropriate serial interface.



**Notice**

**Only 1 CPT6140 can be connected using RS-485. Refer to Figure 5.6.3 for an illustration of a RS-485 wiring arrangement.**

### 5.4 Mounting

The CPT6140 has mounting holes on the side and back per the drawing in 5.2 Dimensions. The CPT6140 can be set up in any orientation since the pressure transducer is relatively insensitive to tilt and vibration. However, excessive motor or machinery vibration of the mounting surface should be avoided to further ensure stability and accuracy. For the greatest accuracy on transducers with a full scale range of less than 15 psi, set CPT6140 zero while it is oriented in its operational position.

## 5.5 Pressure Connections

The pressure to be measured is applied to the port labeled P on top of the CPT6140. The reference connection for gauge pressure is made to the port labeled R. On gauge transducers the reference port is normally left open to atmosphere. If the transducer is used in a differential mode, static line pressures may affect the calibration.



**Warning**

Do not apply more than 30 psi gauge on the reference port!

## 5.6 Electrical Connections

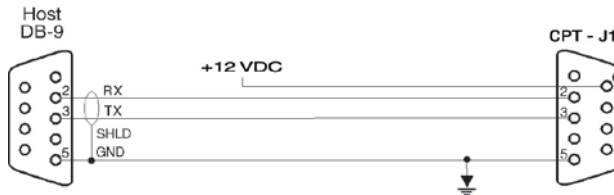

Figure 5.6 - RS-232 Hookup

1. Connectors are female, shown from the wired end.
2. See Table 5.6 for a complete listing of the DB-9 connections.

Table 5.6 - DB-9 Connections

Pin #	RS-232	RS-485
1	N.C.	TA
2	TX	RB
3	RX	RA
4	ANA-	ANA-
5	PWR GND	PWR GND
6	+12 VDC	+12VDC
7	ANA+	ANA+
8	+5Vin	+5Vin*
9	N.C.	TB

\* Use of +5 VDC to power the CPT6140 is not recommended. If required, please consult Mensor for specific power requirements.

# High-Speed Pressure Sensor CPT6140

## 5.6.1 Connector J1 Wiring

Power and signals are applied to J1, a 9-pin D-sub male connector. A nominal 12 VDC supply can be used to power the CPT6140 by applying 12 VDC to pin 6 and ground to pin 5. Power consumption is maximum 55mA at 12 VDC. The CPT6140 is protected against power input reversal. Communication wiring between the host and the CPT6140 is shown in Figures 5.6 and 5.6.3.

## 5.6.2 RS-232 Operation

For RS-232 serial port operation connect the CPT6140 to the host computer. Notice that the host TRANSMIT line is connected to the CPT6140 RECEIVE line (TX to RX), and vice versa. One limitation of the RS-232 bus is that a host can support only one instrument.

## 5.6.3 RS-485 Operation

For RS-485 serial operation, connect the host computer to the CPT6140 per the wire diagram shown in Figure 5.6.3. Notice that the host TRANSMIT lines are connected to the CPT6140 RECEIVE lines, TA to RA, TB to RB, and so on.

Only one RS-485 CPT6140 should be connected to the system, disregard the wiring to “CPT #31” and “CPT6140 #2” in the illustrations. Instead, wire the computer directly to the “CPT #1” by the four-wire method.



**Caution**

**Do not connect more than one CPT6140 at a time to the host computer.**

Terminating resistor examples are shown and should be determined by the end user when cabling extremes are required. Resistor values are selected to match the characteristic impedance of the transmission line, typically 100 to 120 ohms.



**Caution**

**Due to the nature of the various RS-485 converters available there may be communication issues. We have determined that our devices work with the ACCES I/O PRODUCTS devices. At this time we are not in a position to comment on any other make of RS-485 converters and their suitability for use with our products.**

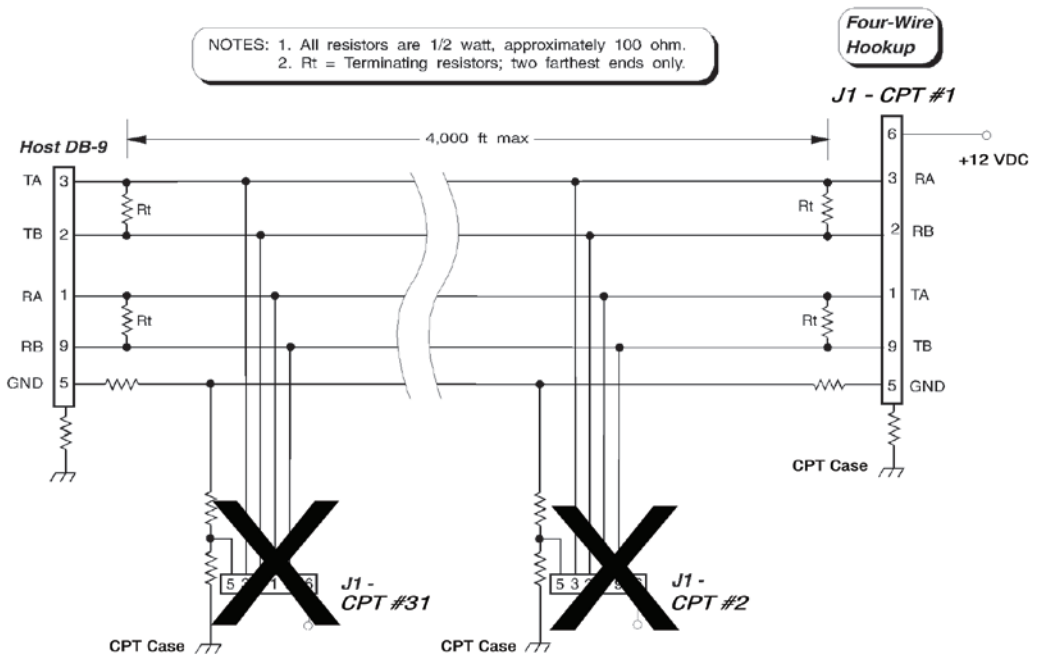

Figure 5.6.3 - RS-485 Cabling

**Note: Multidrop configuration not allowed.**

## 6. Operation



### Caution

**Avoid excessive overpressure to the transducer! Externally mounted relief valves to provide overpressure protection are available from Mensor as optional devices, and are highly recommended for very low pressure transducers.**

User programmable exponential filtering is applied to pressure readings in order to minimize at or near static pressure noise. The filter value can range from 0 (filter OFF) to 99 (maximum filtering). For any positive filter value, the filter is disabled when the pressure change between consecutive readings is greater than 0.025% full scale. However, each pressure change of 0.025% FS, or less, between consecutive readings will apply the exponential filter to the output pressure value to smooth out the readings.

The user can reset the zero and span values via the serial port in order to calibrate the instrument, or the user can change any of several other operating values. The user can also query the device for its current pressure reading, or to find the current settings for other parameters.

# High-Speed Pressure Sensor CPT6140

The serial port is set at the factory for either RS-232 or for RS-485 serial operation according to the customer's instructions. This section of the manual provides information on the serial port configuration, explains the command conventions used in this manual, and lists the common commands and queries which are recognized by the CPT6140.

## 6.1 Serial Port Configuration

Unless otherwise requested by the customer, the CPT6140 serial ports are set at the factory to the default values listed in the following table.

Table 6.2 - Serial Port Settings

Item	Value
Type	RS-232
Address	1
Baud	57600
Data Bits	8
Parity	None
Stop Bits	1

## 6.2 CPT6140 Address

Each CPT6140 is assigned address "1" at the factory. Valid addresses are 0 through 9 and A through Z (upper and lower case are interpreted the same). In addition to the 36 unique addresses available, an asterisk (\*) functions as a wildcard address operator. To change an address see Table 6.5.4 for command set information.



**Note** In burst mode, multidrop is not available.

## 6.3 Communication Output Modes

The output mode is set at the factory to mode 6 on all CPT6140's.

### Mode 6: Burst mode

This is a continuously streaming mode where the pressure value is sent four bytes in IEEE754 (big endian) and a one byte checksum.

Example: 41 E8 A1 CD 97, The first four bytes received are the characters 41 E8 A1 CD which decode to 29.079004 in decimal form using IEEE754 conversion process.

Character 97 is the checksum (one byte truncated) from adding the 4 chars above.

Note that the checksum can be used for synchronization of the packets.

### Mode 3: Query and response mode

This is an ascii response mode that can be used to read pressure, query stored values and cali-



brate the CPT6140. See Section 6.5.4 for commands and queries. When a calibration is performed the CPT6140 must be put into mode 3. All calibration related operations can then be performed per procedures in Section 8. Once calibration is completed the Save command can be sent. Power should then be cycled and new values and pressure reading resultant from calibration can be verified.

After calibration is completed the CPT6140 can be put back into the “burst mode” by sending the mode command with a value of 6. A save must also be sent in order to keep the CPT6140 in mode 6 in case power is cycled.

Note that the CPT6140 can be put into mode 3 and used this way without sending a save command. It will revert back to mode 6 if power is cycled (or mode 6 is sent).



#### Notice

The CPT6140 must be in Mode 3 to calibrate. See Section 8 for calibration procedures and the “M<x>” command in table 6.5.4 for the command used to switch between modes.

## 6.4 Communication Syntax and Command Conventions

All commands and responses are in ASCII characters; lower and upper case are interpreted the same. Every command or query begins with the pound symbol (#). The question mark (?) and decimal point (.) characters are significant to the CPT6140. All other punctuation characters are ignored. Some commands require a password string. A carriage return (<cr>) or linefeed (<lf>) should terminate each command or query.

### 6.4.1 Password Protection

Certain commands require a password to be sent before a setting is changed. The password is only good for one command, so the password string must be sent immediately before any password protected command string. The form of the password string is described in table 6.5.4. However, for calibration protection, the actual password has been replaced with PW in the command string example. See the Password card file for the actual password string to be used in place of PW. When using 2-wire RS-485 configuration, care should be taken to not append the data string with both a carriage return <cr> and a linefeed <lf>. Use one terminator or the other, only. When receiving data from the CPT6140, both a carriage return <cr> and a linefeed <lf> will be sent to terminate the data string. The linefeed <lf> will always be the last character sent by the CPT6140.

### 6.4.2 Response String Format

The CPT6140 will return an R to indicate that it has received a command or password rather than a query. When programming communication with the CPT6140, it is advisable to look for the R response before sending additional commands or queries.

The full command word is shown in Table 6.5.4 in all capital letters. Other conventions used to describe commands are shown in Table 6.5.3.

Table 6.4.2 - Command Conventions

Convention	Description
X	Address (single character 0 through 9 or A through Z; case insensitive)
*	Wildcard address operator
?	Query operator
<sp>	Space ( )
PW	Password; insert password in place of PW (see file on USB drive; case insensitive)
n	One character placeholder for digit or decimal point
n...n	Variable length field
R	Ready response
<cr>	Carriage return
<lf>	Linefeed

## 6.4.3 Commands and Queries



**Each command that changes a parameter is volatile until the SAVE command is issued**

### Notice

Table 6.4.3 - Command Set

Pass- word Protect	Command or Query	Command String	Return String	Description
No	?	#X?<cr>	X<sp>nnnnnnnnn<cr> <lf>	Basic query to return pressure readings.
No	A	#XA<sp>n<cr>	R	Sets address of transducer to 0-9 or A-Z.
No	B?	#XB?<cr>	X<sp>B<sp>n<cr><lf>	Returns the turndown, number.
No	DC?	#XDC?<cr>	X<sp>DC<sp>nnnnn <cr><lf>	Returns the date of calibration where nnnnn is mmdyy.
Yes	DC	#XDC<sp>nnnn n<cr>	R	Loads the date of calibration where nnnnn is mmdyy.
No	FL?	#XFL?<cr>	X<sp>FL<sp>nn<cr> <lf>	Returns the filter – it is the percentage of old reading added to new reading: 0-99.
No	FL	#XFL<sp>nn<cr>	R	Sets the filter percentage.
No	FS?	#XFS?<cr>	X<sp>FS<sp>nnnn<cr> <lf>	Returns the % FS accuracy.



## High-Speed Pressure Sensor CPT6140

4	inH2O@4°C	27.68067
5	inH2O@20°C	27.72977
6	inH2O@60°F	27.70759
7	ftH2O@4°C	2.306726
8	ftH2O@20°C	2.310814
9	ftH2O@60°F	2.308966
10	mtorr (@0°C)	51715.08
11	inSW @ 0°C (3.5% salinity)	26.92334
12	ftSW @ 0°C (3.5% salinity)	2.243611
13	atm	0.06804596
14	Bars	0.06894757
15	mBars	68.94757
16	mmH2O@4°C	703.0890
17	cmH2O@4°C	70.30890
18	mH2O@4°C	0.7030890
19	mmHg@0°C	51.71508
20	cmHg@0°C	5.171508
21	Torr	51.71508
22	Kpa	6.894757
23	Pa	6894.757
24	Dynes/cm2	68947.57
25	g/cm2	70.30697
26	kg/cm2	0.07030697
27	mSW @ 0°C (3.5% salinity)	0.6838528
28	oz/in2	16
29	psf	144
30	tsf	0.072
31	% Full Scale	
32	microns Hg @ 0°C	51715.08
33	tsi	0.0005
35	HPa	68.94757
36	MPa	0.006894757



## **7. Calibration**

The CPT6140 transducer automatically adjusts the pressure readings for the effects of temperature and non-linearity within the calibrated temperature range of 15-45°C. Thus, a calibrated CPT6140 operated within its temperature band, and with proper zero and span settings, will provide accurate pressure measurements.

The transducer should have the span verified periodically to insure its stability. Initially, the recommended period between calibrations is as specified. This period may be extended as confidence is gained in the span stability.

### **7.1 Environment**

Whenever possible, calibrate the CPT6140 at the same ambient temperature as its normal operating environment. The temperature should be stable, and within the specified calibration range. In addition, for maximum accuracy, see that the CPT6140 is at rest on a stable platform which is free of vibration and shock, and oriented similar to its final installation attitude. At the factory the CPT6140 is calibrated vertically with the pressure port at the top.

### **7.2 Equipment**

The following equipment is needed to calibrate a gauge transducer (see Figure 8.2):

1. A downloadable version of the most recent calibration utility program. Go to <http://www.mensor.com>, click "Download", click "Software", click "PC software", then click on Operating & Calibration software for the series CPT6xxx digital pressure transducers. The calibration utility program is also available on CD by request.
2. A host computer with a serial port to match the CPT6140 (RS-232 or RS-485), software to run the CPT6140 transducer, and an appropriate cable.
3. Appropriate pressure and vacuum sources and calibration reference standards for the CPT6140's pressure range.
4. Tubing, fittings and valves adequate for the pressure range.

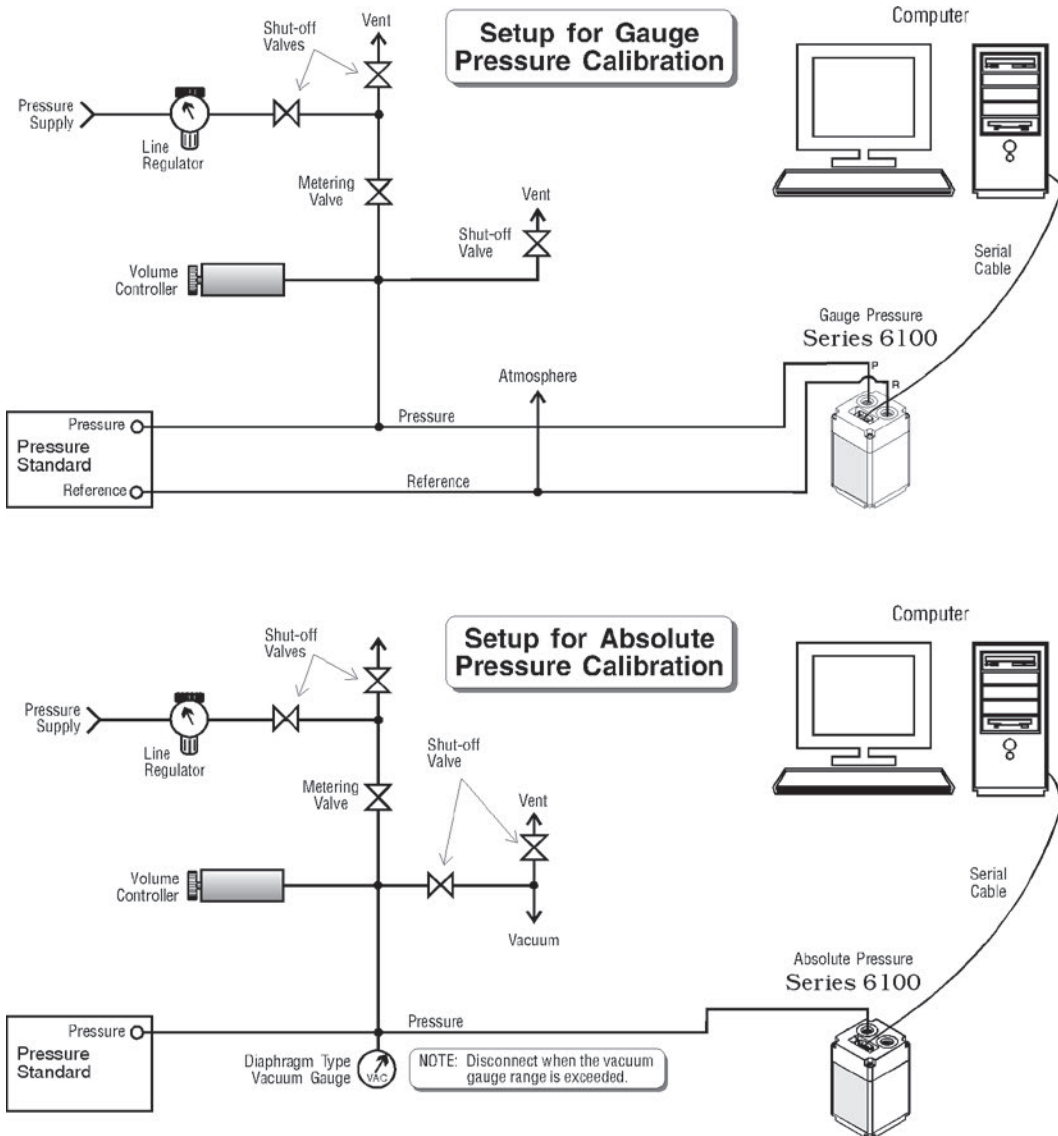

A

Figure 8.2 - Calibration Setup

## 7.3 Pressure Standard

Mensor recommends the use of appropriately accurate primary pressure standards when calibrating this instrument. Such standards should be sufficient so that when the techniques of the ISO Guide to the Expression of Uncertainty in Measurement (GUM) are applied, the instrument meets its accuracy statements as required by ANSI/NCSS Z540, or other applicable standards. The same requirement applies to the vacuum gauge used to set the zero offset on absolute calibrations. The recommended absolute pressure level for setting the zero offset on absolute transducers is between 600 mTorr absolute and 20% of the active transducer's span.

## 7.4 Calibration Medium

The recommended calibration medium for transducers up to 6000 psi is dry nitrogen or clean, dry instrument air. Hydraulic media (water or oil for example) are recommended for ranges above this psi. Hydraulic media can be used with lower ranges, however, special techniques must be used in filling the connection lines and transducer.

## 7.5 Calibration Process

Please notice that the commands listed in this section are shown in the same style as those in the Operation section. These are the bare commands seen by the CPT6140, stripped of all programming idioms. Depending on the specific language used to generate them, these commands may have to be preceded by or enclosed in various symbols for transmission. For this procedure it is assumed that a single CPT6140 is connected to the host computer, and that its assigned address is unknown.

The model, serial number, and software version number of the CPT6140 being calibrated can be obtained by sending: `#*ID?<cr>`.

## 7.6 Correction Value Query

The stored correction for zero offset or the span correction factor can be retrieved over the bus. The returned values have six significant digits plus a decimal point and a sign. To see the stored values send either:

`#*ZC?<cr>` or `#*SC?<cr>`

These commands may be useful in determining the actual changes in zero and span over time. Unauthorized alterations of the values can be detected by comparison with previously recorded correction values.

**Each command issued to either calibration parameter must be followed by the SAVE command to make it permanent. Otherwise, the changes will be lost the next time the CPT6140 loses power.**



## 7.7 Zero Adjustment

To adjust zero, first determine the correct zero offset, then send the password, and then send the new zero value. Applying the correct zero pressure and finding the resulting zero offset is different for an absolute transducer than it is for a gauge type unit. Once the zero offset is known, the procedure for sending the zero correction value (which sets the output to zero) is the same for either type of transducer. When the zero offset is correct, issue a SAVE command to preserve it in non-volatile memory.

### 7.7.1 Gauge Zero Offset

Substitute the required password in place of “PW” in the following examples:

1. Determine the current zero offset and make a note of the returned reading.  
Next send: `#*ZC?<cr>`  
Record the date and this reading to track zero changes between calibrations.
2. Vent the PRESSURE and REFERENCE ports to atmosphere.  
The true pressure is now 0 (zero).  
Send: `#*PW<cr>`  
Next send: `#*ZC<sp>0<cr>`  
This will clear the current zero offset from RAM.
3. While vented, determine the current zero pressure reading of the CPT6140.  
Send: `#*?<cr>`  
Make a note of the zero value returned by the CPT6140.
4. Subtract the current zero reading from true zero.  
The difference is the new zero offset.

Example: For a 0-30 psi unit with both ports vented:

True Pressure = 0 (vented)

Current Pressure reading (from step 4) = +0.0023 psi

True Pressure – Current Pressure = New Offset

0.0000 (–) +0.0023 = –0.0023 psi offset

5. Enter the new offset into memory.  
Send: `#*PW<cr>`  
Next send the zero offset: `#*ZC<sp>-.0023<cr>`  
The new offset of –0.0023 will now be added to all pressure readings of the CPT6140.  
Send: `#*SAVE<cr>` to store the new value in non-volatile memory.
6. To check the zero correction:  
Send: `#*?<cr>`  
The reading returned should be 0.0000 psi with both ports vented.

## 7.7.2 Absolute Zero Offset

Substitute the required password in place of “PW” in the following examples:

1. Find the current zero offset and make a note of the returned value.  
Send: `#*ZC?  
<cr>` and record the reading.
2. Use the setup for absolute pressure shown in Figure 8.2. Apply a stable pressure value between 600 mTorr absolute and 20% of the transducer’s span. Measure the reference pressure reading in the native units of the CPT6140. This reading becomes the “true pressure”.
3. Clear the current zero offset from RAM.  
Send: `#*PW  
<cr>`  
Next send: `#*ZC 0  
<cr>`
4. Determine the current pressure reading.  
Send: `#*?  
<cr>` and make a note of this reading.
5. Subtract the current pressure reading from the true pressure (vacuum) reading.  
The difference is the zero offset now required.

Example: For a 0-15 psia unit with 600 mTorr absolute pressure applied, using psi units:  
600 millitorr = 0.0116 psia (True Pressure)  
Current Pressure reading (from step 4) = -0.0011 psia  
True Pressure – Current Pressure = New Offset  
 $0.0116 - (-0.0011) = +0.0105$  psi offset

6. Enter the new offset into memory.  
Send: `#*PW  
<cr>`  
Then send: `#*ZC  
<sp>.0105  
<cr>`  
The new offset of 0.0105 will now be added to all pressure readings.  
Send: `#*SAVE  
<cr>` to store the new value in non-volatile memory.
7. To check the zero correction:  
Send: `#*?  
<cr>`  
For 600 mTorr the pressure reading returned should be 0.0116 psia.

## 7.8 Span Adjustment

The span adjustment procedure is the same for gauge and absolute units. Always make zero corrections before changing the span factor. A scale factor within the range of 0.9 to 1.1 is used as a multiplier to correct for span shifts.

1. Determine the current span scale factor and record the reading.

Send: `#*SC?<cr>`

This reading can be used at some later date to detect a span change between calibrations.

2. To clear the current scale factor:

Send: `#*PW<cr>`

Next send: `#*SC<sp>1<cr>`

3. Apply a known true pressure equal to the span of the CPT6140.

To determine the CPT6140 pressure reading:

Send: `#*?<cr>` and make a note of this reading.

4. Divide the known true pressure by the CPT6140 pressure reading.

The result is the required new span scale factor.

Example: For a 150 psi unit:

True pressure = 150.003 psi

CPT6140 pressure reading (from step 3) = 149.984 psi

True pressure/CPT6140 pressure = New Span Scale Factor

$150.003/149.984 = 1.000127$

5. To enter the new span scale factor:

Send: `#*PW<cr>`

Then send: `#*SC<sp>1.000127<cr>`

Send: `#*SAVE<cr>` to store the new value in non-volatile memory.

All future pressure readings returned by this CPT6140 will be multiplied by a scale factor of 1.000127 before they are transmitted over the bus.

6. To check the span reading:

Send: `#*?<cr>`

The returned pressure value should be 150.003 psi, if the pressure has not changed.



**Mensor**

201 Barnes Drive  
San Marcos, Tx 78666  
Tel: 512-396-4200  
Fax: 512-396-1820  
sales@mensor.com  
www.mensor.com



**WIKAI Alexander Wiegand SE & Co. KG**

Alexander-Wiegand-Straße 30  
D-63911 Klingenberg / Germany  
Tel: +49 93 72/132-5015  
Fax: +49 93 72/132-8767  
CTSales@wika.de  
www.wika.de